

NORMAL

MWO effective date 1 June 1992 and completion date 30 May 1994

MWO 9-2320-279-34-1

MODIFICATION WORK ORDER

MODIFICATION OF M977 SERIES HEAVY EXPANDED MOBILITY TACTICAL TRUCK (HEMTT) INSTALLATION INSTRUCTIONS FOR THREE POINT SEAT BELTS

MODEL	NSN
TRUCK, CARGO, W/WINCH M977	2320-01-097-0260
TRUCK, CARGO, W/O WINCH M977	2320-01-099-6426
TRUCK, TANK, FUEL, W/WINCH M978	2320-01-097-0249
TRUCK, TANK, FUEL, W/O WINCH M978	2320-01-100-7672
TRUCK, TRACTOR W/WINCH W/O CRANE M983	2320-01-097-0247
TRUCK, WRECKER, W/WINCH M984	2320-01-097-0248
TRUCK, WRECKER, W/WINCH M984A1	2320-01-195-7641
TRUCK, CARGO, W/WINCH M985	2320-01-097-0261
TRUCK, CARGO, W/O WINCH M985	2320-01-100-7673
TRUCK, CARGO, W/WINCH M985E1	2320-01-194-7032

HEADQUARTERS, DEPARTMENT OF THE ARMY, WASHINGTON, DC

1 JULY 1992

REPORTING OF ERRORS AND RECOMMENDING IMPROVEMENTS

You can help improve this MWO. If you find any mistakes or if you know away to improve the procedures, please let us know. Write a letter, or complete and mail in a DA Form 2028 (Recommended Changes to Publications and Blank Forms), direct to: Commander, U.S. Army Tank-Automotive Command, Attn: AMSTA-MB, Warren, MI 48397-5000. A reply will be furnished to you.

Approved for public release; distribution is unlimited.

CHANGE

NO. 1

HEADQUARTERS
DEPARTMENT OF THE ARMY
Washington D. C., 1 November 1992

MODIFICATION WORK ORDER
MODIFICATION OF M977 SERIES HEAVY EXPANDED MOBILITY
TACTICAL TRUCK (HEMTT)
INSTALLATION INSTRUCTIONS FOR
THREE POINT SEAT BELTS

MODEL	NSN
TRUCK, CARGO, W/WINCH, M977	2320-01-097-0260
TRUCK, CARGO, W/O WINCH, M977	2320-01-099-6426
TRUCK, TANK, FUEL, W/WINCH, M978	2320-01-097-0249
TRUCK, TANK, FUEL, W/O WINCH, M978	2320-01-100-7672
TRUCK, TRACTOR, W/WINCH, W/O CRANE, M983	2320-01-097-0247
TRUCK, WRECKER W/WINCH, M984	2320-01-097-0248
TRUCK, WRECKER W/WINCH, M984A1	2320-01-195-7641
TRUCK, CARGO, W/WINCH, M985	2320-01-097-0261
TRUCK, CARGO, W/O WINCH, M985	2320-01-100-7673
TRUCK, CARGO, W/WINCH, M985E1	2320-01-094-7032

MWO 9-2320-279-34-1 dated 1 July 1992, is changed as follows:

1. Remove old pages and insert new pages as indicated below.
2. New or changed information is indicated by a vertical bar in the margin of the page.
3. Minor changes to illustrations are indicated by a miniature pointing hand.
4. Illustrations that are new or that have major revisions are indicated by a vertical bar adjacent to the illustration identification number.

Remove Pages

Insert Pages

Cover and 2

Cover and 2

3. File this change sheet in front of the publication for reference purposes.

APPROVED FOR PUBLIC RELEASE; DISTRIBUTION IS UNLIMITED

By Order of the Secretary of the Army:

GORDON R. SULLIVAN
General, United States Army
Chief of Staff

Official:

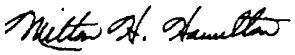
MILTON H. HAMILTON
Administrative Assistant to the
Secretary of the Army
03238

Distribution:

To be distributed in accordance with DA Form 12-38-E (Block 0866) Direct and General Support maintenance requirements for MWO 9-2320-279-34-1.

1. **PURPOSE.** The installation of the kit contained in this MWO is intended to provide a safer environment for the HEMTT operator and passenger.
2. **PRIORITY.** This modification is classified as NORMAL.
3. **END ITEM TO BE MODIFIED.** Refer to Table 1.

Table 1. End Items to be Modified

Nomenclature	NSN	PN	CAGE	Model	Serial No. Range
Truck, Cargo, w/Winch	2320-01-097-0260	XM977WW	19207	M977	40005 and below
Truck, Cargo, w/o Winch	2320-01-099-6426	XM977WOW	19207	M977	
Truck, Tank Fuel, w/Winch	2320-01-097-0249	XM978WW	19207	M978	
Truck, Tank, Fuel, w/o Winch	2320-01-100-7672	XM978WOW	19207	M978	
Truck, Tractor w/Winch w/o Crane	2320-01-097-0247	XM983WOC	19207	M983	
Truck, Wrecker, w/Winch	2320-01-097-0248	XM984WW	19207	M984	
Truck, Wrecker, w/Winch	2320-01-195-7641	XM984A1WW	19207	M984A1	
Truck, Cargo, w/Winch	2320-01-097-0261	XM985W	19207	M985	
Truck, Cargo, w/o Winch	2320-01-100-7673	XM985WOW	19207	M985	
Truck, Cargo, w/Winch	2320-01-194-7032	XM985E1WW	19207	M985E1	

4. **MODULE (COMPONENTS, ASSEMBLIES, SUBASSEMBLIES, BOARDS, AND CARDS) TO BE MODIFIED.** The following item whether installed or in depot stock, shall be modified prior to issue and shall be marked so that it can be easily determined that modification has been accomplished. Refer to Table 2.

Table 2. Parts to be Modified

NOMENCLATURE	NSN	PN	CAGE
Cab Assembly	2510-01-193-1745	1310710U	45152

5. **PARTS TO BE MODIFIED.** Not applicable.

6. APPLICATION.

- a. Time Compliance Schedule. The effective date of this MWO is 1 June 1992 and its completion date is 30 May 1994.
- b. Lowest Level of Maintenance Authorized to Apply the MWO: Direct Support.
- c. Work Force and Man-Hour Requirements for Application of this MWO to a Single Unit, End Item or System is as follows:

REQUIREMENTS

WORK FORCE/SKILLS

MAN-HOURS

Heavy Wheeled Vehicle Mechanic
(MOS 63S) (1)

3.5

Total man-hours required for a single application of this MWO is 3.5 hours.

- d. MWO's to be applied to or Concurrently with the Application of this MWO: Not applicable

7. TECHNICAL PUBLICATIONS AFFECTED/CHANGED. Refer to Table 3.

Table 3. Publications Affected

Publication	Date
TM 9-2320-279-10-1	November 1986
TM 9-2320-279-20-2	April 1987
TM 9-2320-279-20P	March 1988
TM 9-2320-279-34P	March 1988

8. MWO KITS/PARTS AND THEIR DISPOSITION.

a. Kits/Parts Needed to Apply this MWO.

(1) The parts listed in Table 4 are required to accomplish this MWO.

Table 4. Part and Security Classification

Nomenclature	NSN	PN	CAGE	Qty	Classification
Three Point Seat Belt Kit	2540-01-293-8331	3SK652	45152	1	Unclassified
Consists of:					
Screw, 0.44-15 x 3.25	5305-01-354-2488	2816HX	45152	2	Unclassified
Locknut, 0.44-14	5310-00-241-6659	MS51943-37	96906	4	Unclassified
Washer, 0.44 HDW	5310-00-184-8628	MS 15795-816	96906	8	Unclassified
Screw, 0.44-14 x 3.00	5306-00-087-0787	MS 16208-86	96906	2	Unclassified
Lockwasher, 0.44	5310-01-081-1283	352-A	45152	4	Unclassified
Screw, 0.44-20 x 3.00	5305-01-354-2487	1773HX1	45152	4	Unclassified
Seat Belt Kit, 3 Point including:		1708550	45152	2	Unclassified
Locator Bracket				1	Unclassified
Flat Washers 0.44 HDW			45152	4	Unclassified
Bushing (1) 0.56				1	Unclassified

(2) Kit shipping data:
 Weight 5 lbs.
 Volume 0.2 cu. ft.

- b. Contents of MWO Kits: Refer to Table 4.
- c. Bulk and Expendable Material: Not applicable.
- d. Parts Disposition: Not applicable.

9. SPECIAL TOOLS: JIGS; TEST MEASUREMENT AND DIAGNOSTIC EQUIPMENT (TMDE); AND FIXTURES REQUIRED. Not applicable.

10. MODIFICATION PROCEDURES.

a. Preparation for Installation of Three-Point Seat Belt.

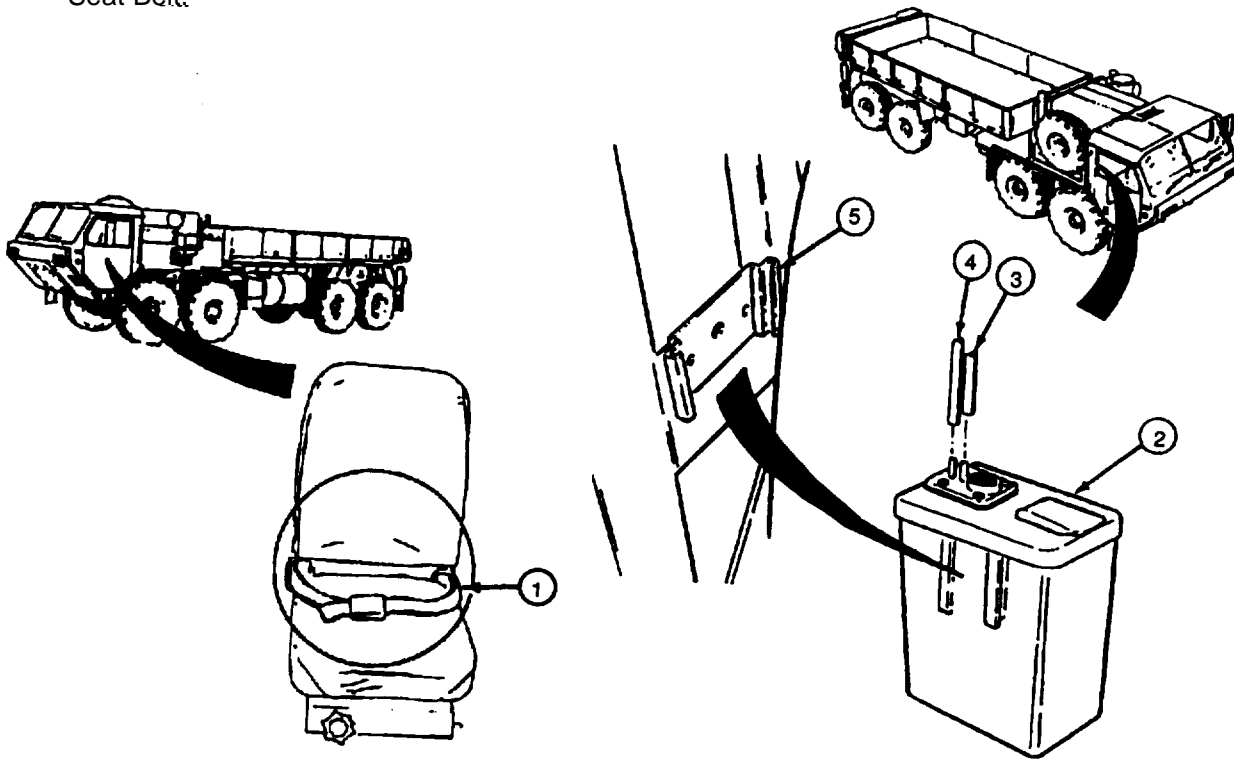

(4) If a gas particulate kit is installed, remove valve (6), connector (7), and retaining ring (8). If a gas particulate kit is not installed, go to step 6.

NOTE

Use existing fasteners unless otherwise shown in procedure.

- (1) Remove two lap belts (1) in accordance with TM 9-2320-279-20, para 16-32. Save fasteners.

NOTE

Tag and mark hoses before removal.

- (2) If windshield washer reservoir (2) is installed behind the passenger seat, remove air hose (3) and fluid hose (4) from the reservoir.
- (3) Remove reservoir (2) from bracket (5).

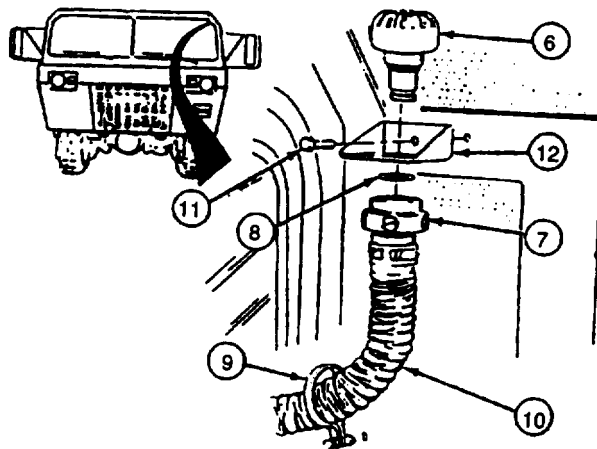

(5) Remove clip (9) and hose (10). Move hose (10) out of the way.

(6) Remove screw (11) and, if installed, hanger (12).

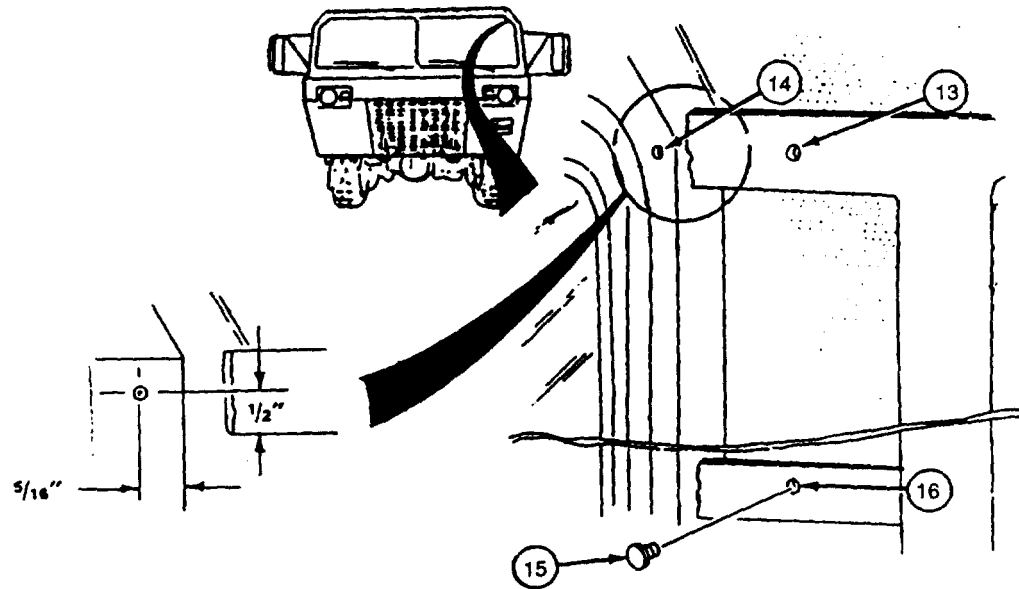

- (7) Drill 1/2 inch bracket mounting hole (13) through cab for mounting of D-loop (in three-point seat belt kit).
- (8) Lay out new bracket mounting hole (14) as indicated.
- (9) Center punch and drill hole (14) to 1/4 inch. Deburr hole.
- (10) Remove plug (15) and drill 1/2 inch hole. Deburr hole.
- (11) Remove plug (17).

NOTE

If a hose clip and hose are attached to the cab with the plug used in step (11), do step (12) through (15). If a hose is not attached, perform step (13) and proceed to paragraph b.

- (12) Remove hose (18) and clip (19).
- (13) Drill 1/2 inch hole (20) through cab. Deburr hole.
- (14) Lay out new plug mounting hole (21) as indicated.
- (15) Center punch and drill hole (21) to 1/4 inch. Deburr hole.

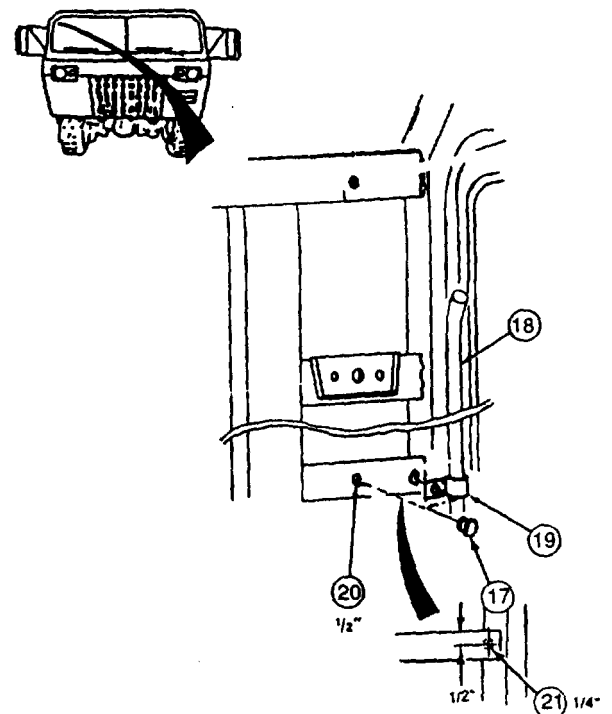

b. Installation instructions.

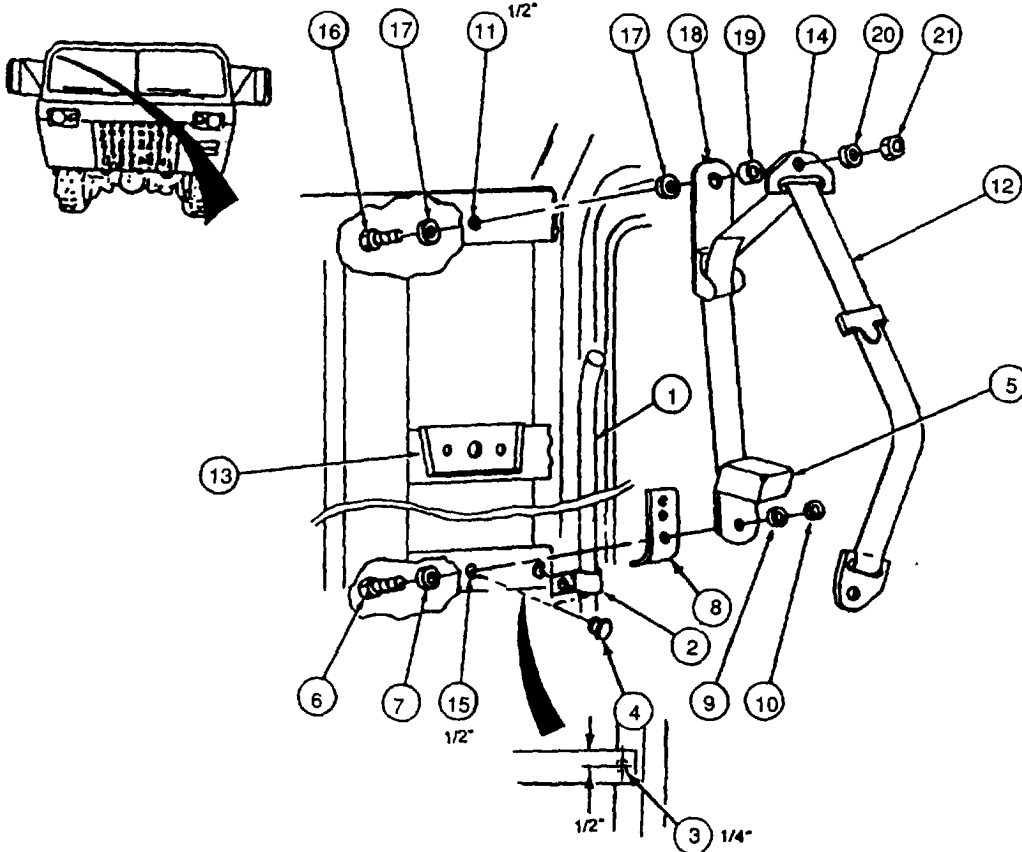

- (1) If removed, install hose (1) and hose clip (2) in hole (3) with plug (4).
 - (2) Pull cover of passenger side retractor (5) away and install retractor with screw (6), washer (7), bracket (8), washer (9) and locknut (10). Do not tighten.
 - (3) Lay out position of passenger side D-loop mounting hole (11) by centering belt (12) in bracket (13) and using D-loop (14) to locate hole as shown. Make sure hole (15) and hole (11) align with hole in center of bracket (13).
 - (4) Center punch and drill hole (11) to 1/2 inch. Deburr hole.
 - (5) Install passenger side D-loop (14) with 0.44-15 x 3.25 inch screw (16), two 0.44 inch HOW washers (17), Komfort-Latch bracket (18), 0.56 inch bushing (19), 0.44 inch HDW washer (20), and 0.44-14 lock nut (21). Torque to 35 lb-ft (47N-m).
- NOTE**
- Make sure belt is not twisted, and is centered in windshield washer bracket. Belt must move freely between bracket and windshield washer reservoir when installed.
 - Komfort-Latch must be mounted vertically in line with belt, hang directly below D-loop mounting, and remain rigid after tightening.
 - D-loop and washers must still move freely after screw is tightened.
 - D-loop must be free to return to horizontal position when belt is removed and retracted.
 - (6) Tighten locknut (10) and snap cover of retractor (5) shut.

NOTE

- Interconnect and tether must just be free to rotate after nut is tightened.
- Interconnect must be positioned 45 degrees frontward and up.
- Tether must be positioned 45 degrees rearward and down

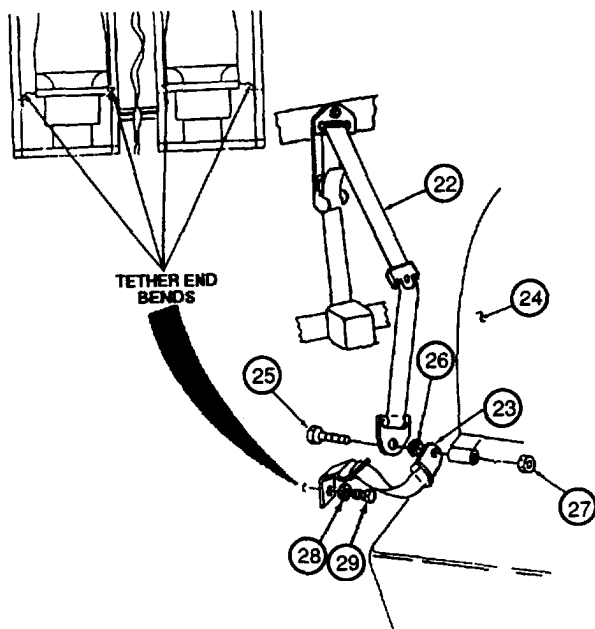

- (9) Pull cover (30) of interconnect (31) away and install washer (32), interconnect (31), washer (33), tether (34) and washer (35) with screw (36) and locknut (37). Torque to 40 lb-ft (54 N-m) and snap cover shut.
- (10) Install other end of tether (34) into existing hole from removed tether with 0.44 inch HDW lockwasher (38) and 0.44-20 x 1.00 inch screw (39).
- (11) Do steps (2), and (5) through (10) for driver's side seat.

NOTE

- Belt end and tether must be just free to rotate after nut is tightened.
- Tether must be positioned 45 degrees rearward and down.
- Tether end bends must be positioned as shown in illustration.

- (7) Install belt end (22) and tether (23) on seat (24) with screw (25), washer (26), and locknut (27). Torque to 40 lb-ft (54 N-m).
- (8) Install other end of tether (23) into existing hole from removed tether with 0.44 inch lockwasher (28) and 0.44-20 x 1.00 inch screw (29) from kit furnished items.

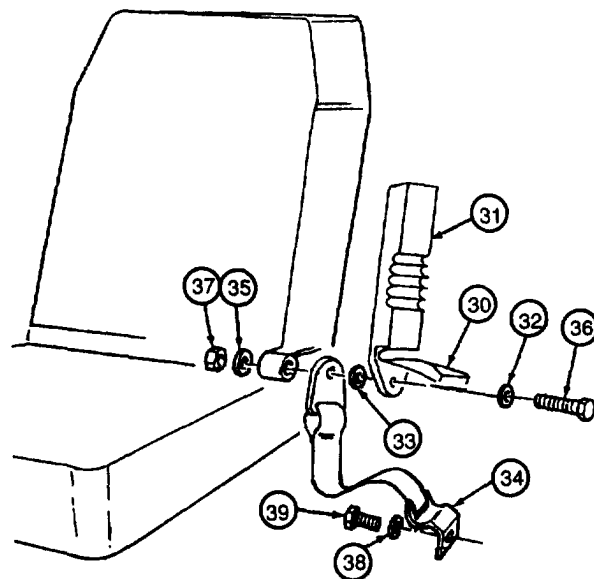

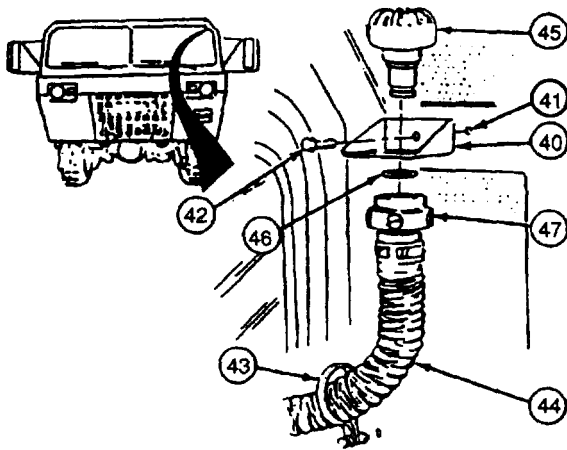

NOTE

If gas particulate filter is not installed, install screw only.

(12) If a gas particulate kit is installed, install hanger (40) in new hole (41) with screw (42). If a gas particulate kit is not installed, go to step (15).

(13) Install clip (43) and hose (44).

(14) Install valve (45), retaining ring (46), and connector (47).

(15) Install reservoir (48) on bracket (49). Ensure seat belt strap moves freely.

(16) Install fluid hose (50) and air hose (51) on reservoir (46).

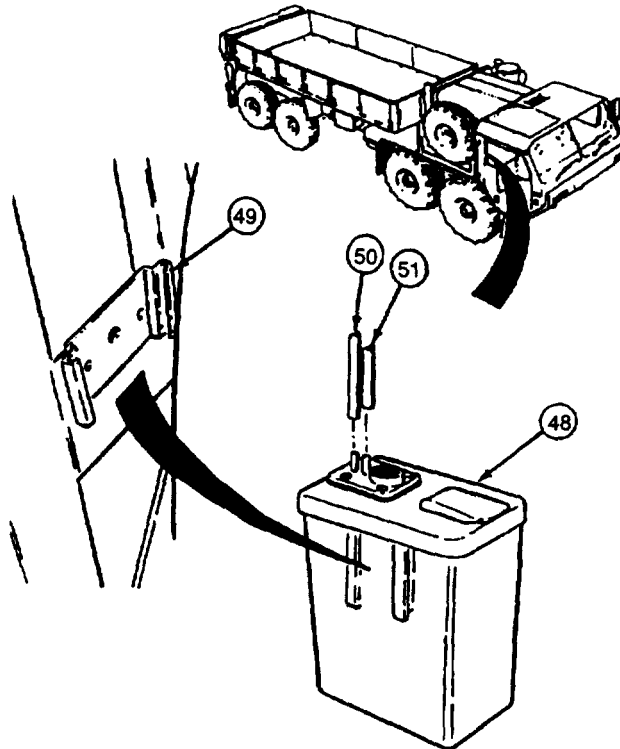

END OF TASK

11. CALIBRATION REQUIREMENTS. Not applicable.

12. WEIGHT AND BALANCE DATA. Weight and balance are not significantly affected.

13. QUALITY ASSURANCE REQUIREMENTS. Not Applicable.

14. RECORDING AND REPORTING OF THE MODIFICATION. Record the modification in accordance with AR 750-10, DA PAM 738-750, DA PAM 738-751, and TB 9-1100-803-15.

15. PRODUCT IMPROVEMENT PROPOSAL (PIP) NUMBER. This MWO is authorized by PIP number 1-89-06-4216.

16. MODIFICATION IDENTIFICATION. Refer to paragraph 10. Three point seat belts will be immediately noticeable to users.

By Order of the Secretary of the Army:

GORDON R. SULLIVAN
General, United States Army
Chief of Staff

Official

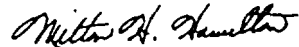

MILTON H. HAMILTON
Administrative Assistant to the
Secretary of the Army

02031

Distribution

To be distributed in accordance with DA Form 12-38-E (Block 0866) Direct and General Support maintenance requirements for MWO9-2320-279-34-1.

RECOMMENDED CHANGES TO EQUIPMENT TECHNICAL PUBLICATIONS



THEN...JOT DOWN THE DOPE ABOUT IT ON THIS FORM. CAREFULLY TEAR IT OUT, FOLD IT AND DROP IT IN THE MAIL.

SOMETHING WRONG WITH PUBLICATION

FROM: (PRINT YOUR UNIT'S COMPLETE ADDRESS)

DATE SENT

PUBLICATION NUMBER

PUBLICATION DATE

PUBLICATION TITLE

BE EXACT PIN-POINT WHERE IT IS

PAGE NO.

PARA-GRAPH

FIGURE NO.

TABLE NO.

IN THIS SPACE, TELL WHAT IS WRONG AND WHAT SHOULD BE DONE ABOUT IT.

TEAR ALONG PERFORATED LINE

PRINTED NAME, GRADE OR TITLE AND TELEPHONE NUMBER

SIGN HERE

THE METRIC SYSTEM AND EQUIVALENTS

WEIGHT MEASURE

1 Centimeter = 10 Millimeters = 0.01 Meters = 0.3937 Inches
 1 Meter = 100 Centimeters = 1000 Millimeters = 39.37 Inches
 1 Kilometer = 1000 Meters = 0.621 Miles

WEIGHTS

1 Gram = 0.001 Kilograms = 1000 Milligrams = 0.035 Ounces
 1 Kilogram = 1000 Grams = 2.2 lb.
 1 Metric Ton = 1000 Kilograms = 1 Megagram = 1.1 Short Tons

LIQUID MEASURE

1 Milliliter = 0.001 Liters = 0.0338 Fluid Ounces
 1 Liter = 1000 Milliliters = 33.82 Fluid Ounces

SQUARE MEASURE

1 Sq. Centimeter = 100 Sq. Millimeters = 0.155 Sq. Inches
 1 Sq. Meter = 10,000 Sq. Centimeters = 10.76 Sq. Feet
 1 Sq. Kilometer = 1,000,000 Sq. Meters = 0.386 Sq. Miles

CUBIC MEASURE

1 Cu. Centimeter = 1000 Cu. Millimeters = 0.06 Cu. Inches
 1 Cu. Meter = 1,000,000 Cu. Centimeters = 35.31 Cu. Feet

TEMPERATURE

$5/9(^{\circ}\text{F} - 32) = ^{\circ}\text{C}$
 212° Fahrenheit is equivalent to 100° Celsius
 90° Fahrenheit is equivalent to 32.2° Celsius
 32° Fahrenheit is equivalent to 0° Celsius
 $9/5^{\circ}\text{C} + 32 = ^{\circ}\text{F}$

APPROXIMATE CONVERSION FACTORS

TO CHANGE	TO	MULTIPLY BY
Inches	Centimeters	2.540
Feet	Meters	0.305
Yards	Meters	0.914
Miles	Kilometers	1.609
Square Inches	Square Centimeters	6.451
Square Feet	Square Meters	0.093
Square Yards	Square Meters	0.836
Square Miles	Square Kilometers	2.590
Acres	Square Hectometers	0.405
Cubic Feet	Cubic Meters	0.028
Cubic Yards	Cubic Meters	0.765
Fluid Ounces	Milliliters	29.573
its	Liters	0.473
arts	Liters	0.946
allons	Liters	3.785
Ounces	Grams	28.349
Pounds	Kilograms	0.454
Short Tons	Metric Tons	0.907
Pound-Feet	Newton-Meters	1.356
Pounds per Square Inch	Kilopascals	6.895
Miles per Gallon	Kilometers per Liter	0.425
Miles per Hour	Kilometers per Hour	1.609

TO CHANGE	TO	MULTIPLY BY
Centimeters	Inches	0.394
Meters	Feet	3.280
Meters	Yards	1.094
Kilometers	Miles	0.621
Square Centimeters	Square Inches	0.155
Square Meters	Square Feet	10.764
Square Meters	Square Yards	1.196
Square Kilometers	Square Miles	0.386
Square Hectometers	Acres	2.471
Cubic Meters	Cubic Feet	35.315
Cubic Meters	Cubic Yards	1.308
Milliliters	Fluid Ounces	0.034
Liters	Pints	2.113
Liters	Quarts	1.057
ers	Gallons	0.264
ms	Ounces	0.035
ograms	Pounds	2.205
Metric Tons	Short Tons	1.102
Newton-Meters	Pounds-Feet	0.738
Kilopascals	Pounds per Square Inch	0.145
ometers per Liter	Miles per Gallon	2.354
ometers per Hour	Miles per Hour	0.621



PIN: 070133-001